

# 4

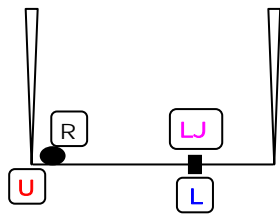

**Measurements**

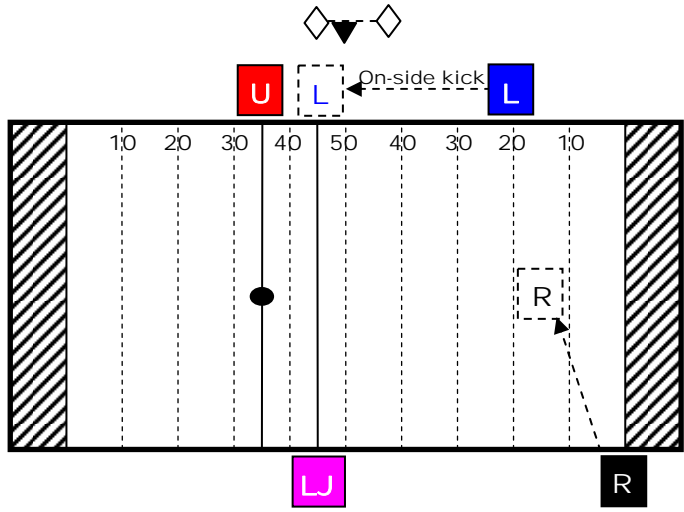

**Kickoff Positions**

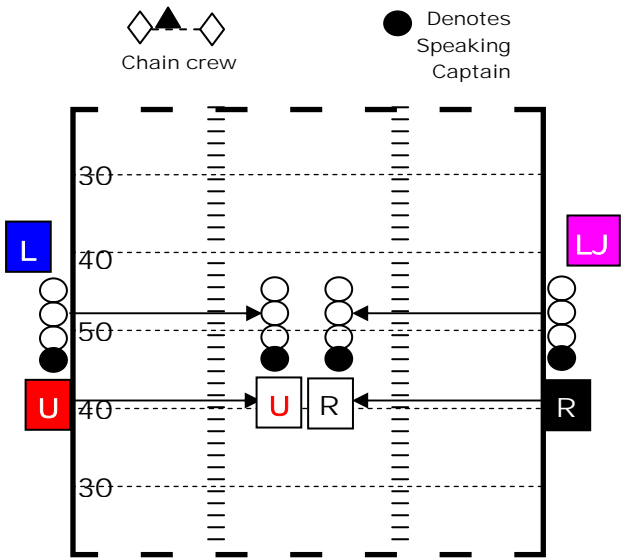

**Prior to Coin Toss**

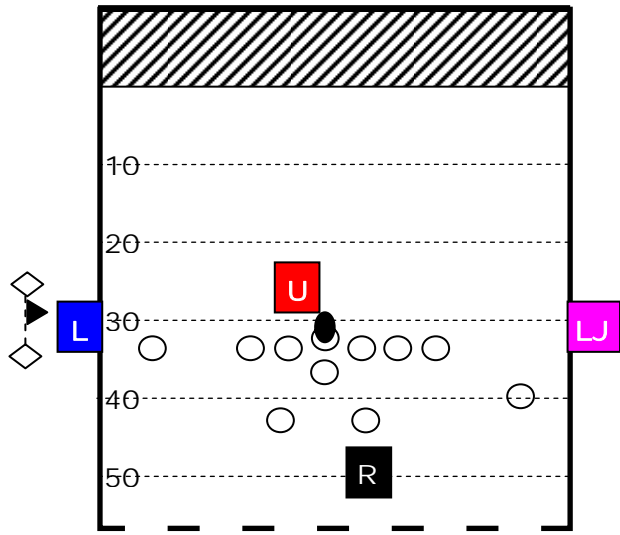

**Standard Positions**

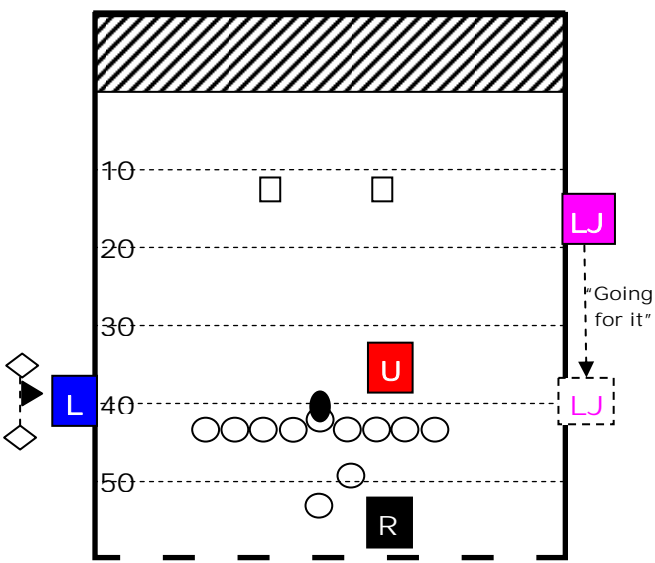

**Scrimmage kick**

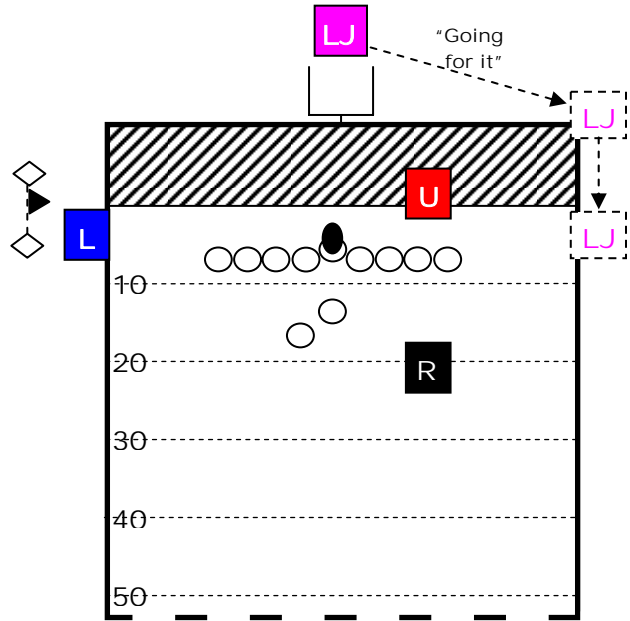

**1 point PAT or field goal attempt**

# 5

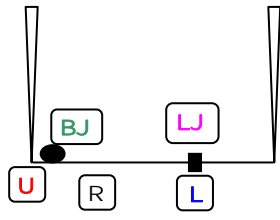

**Measurements**

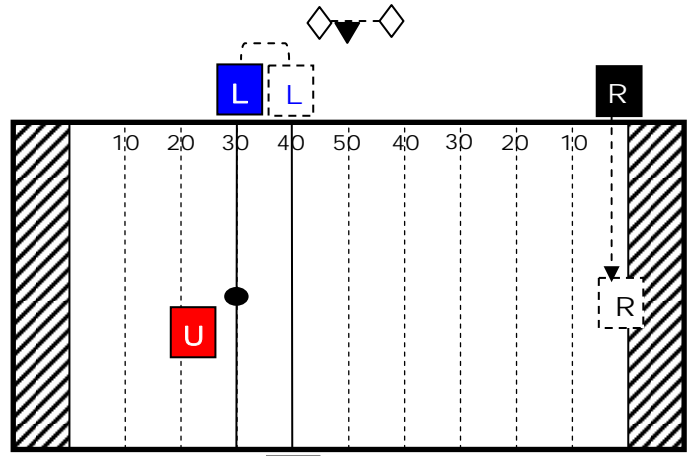

**Kickoff Positions**

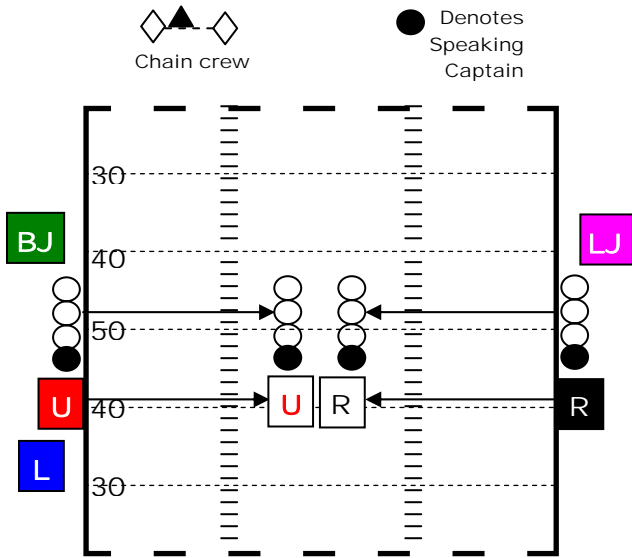

**Prior to Coin Toss**

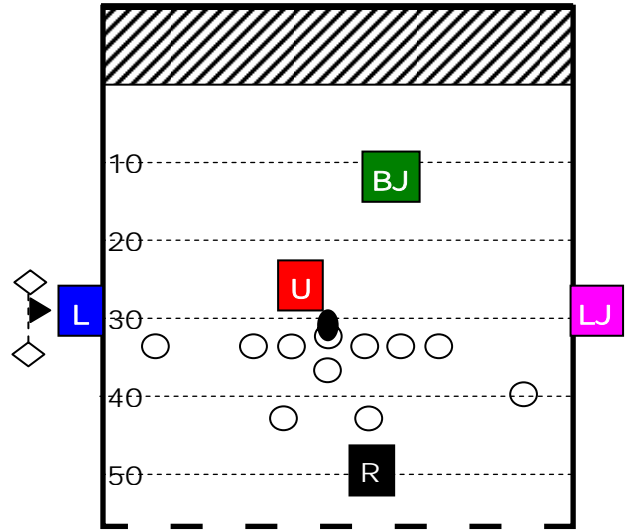

**Standard Positions**

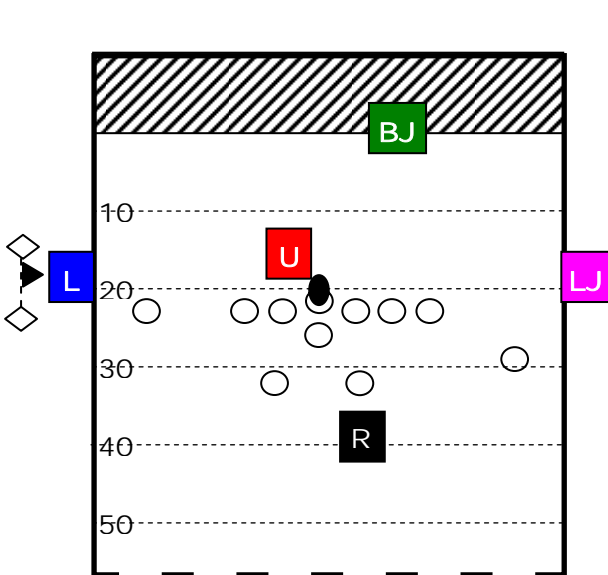

**Inside 20**

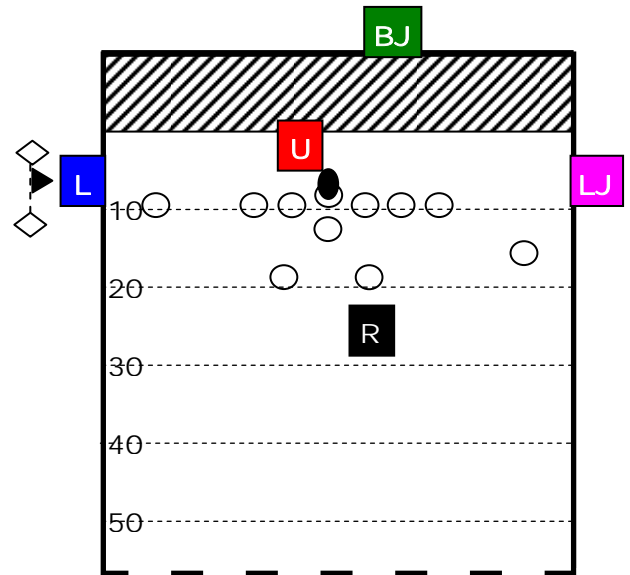

**Inside 10**

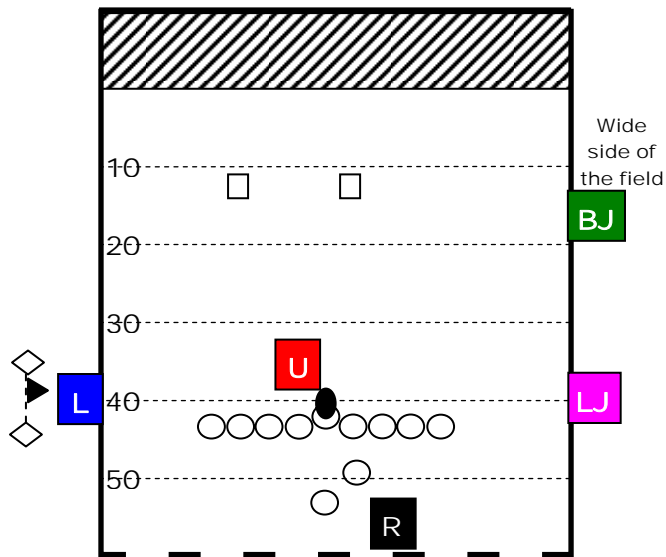

**Scrimmage kick**

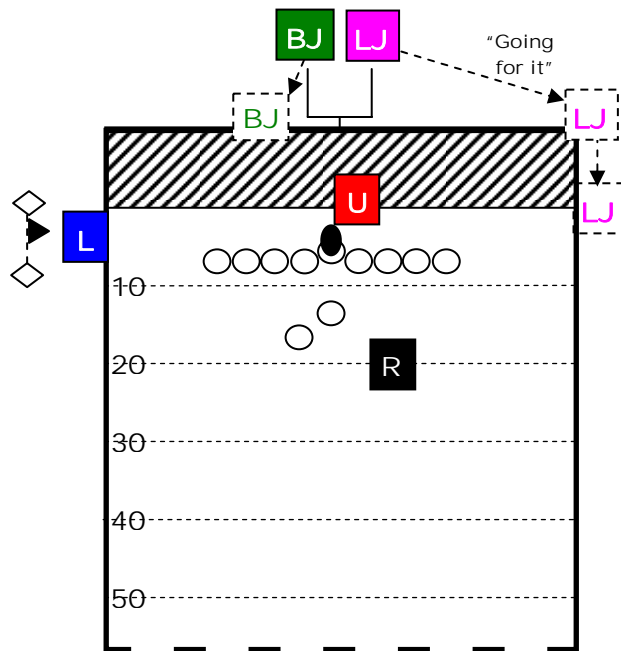

**1-point PAT or field goal attempt**

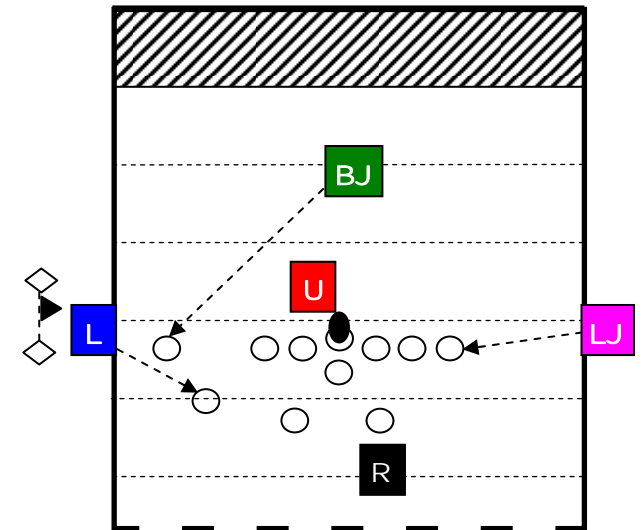

**Initial keys: Standard**  
(BJ has widest receiver on strong side)

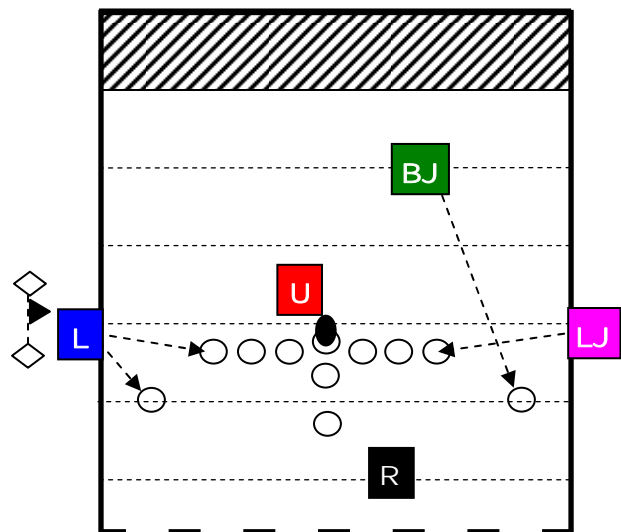

**Balanced formation**  
(Strength declared to LJ's side)

5

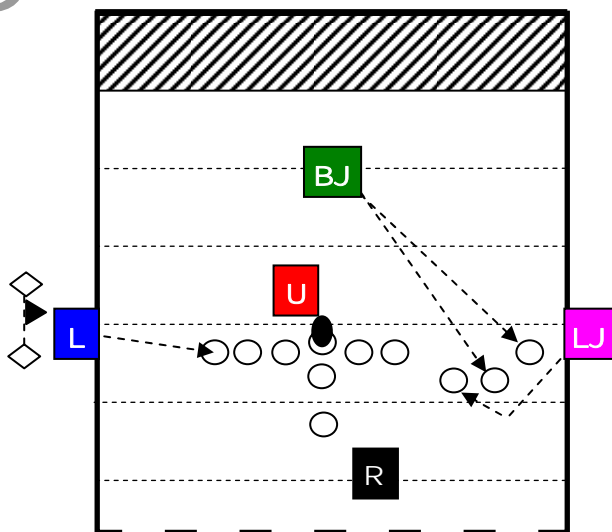

**Trips**  
(BJ has 2 widest receivers)

5

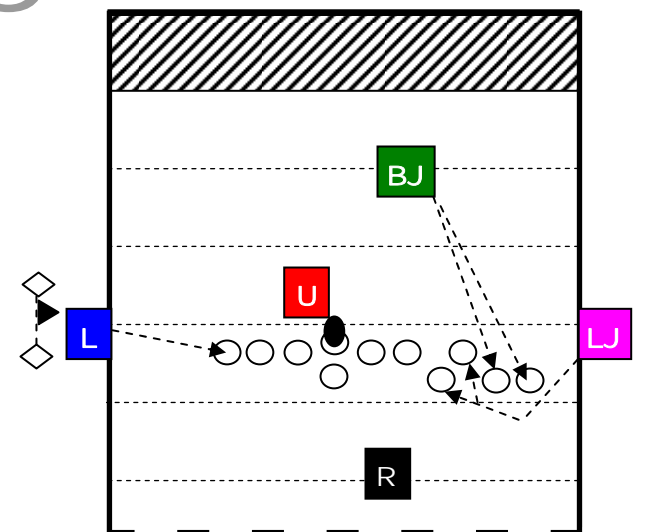

**Four receivers**  
(If stacked, BJ has front two receivers)

# 6

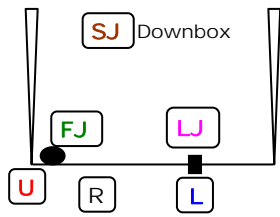

**Measurements**

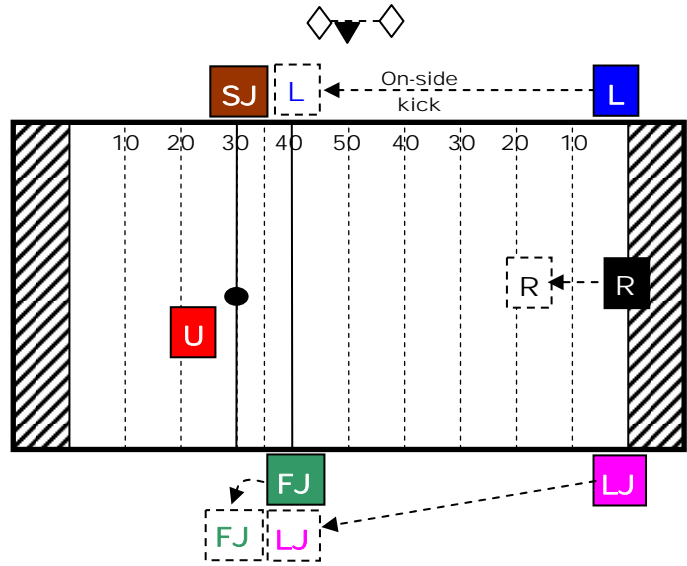

**Kickoff Positions**

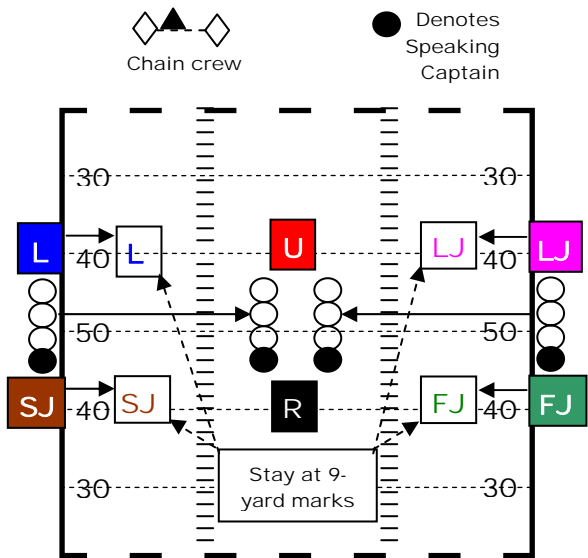

**Prior to Coin Toss**

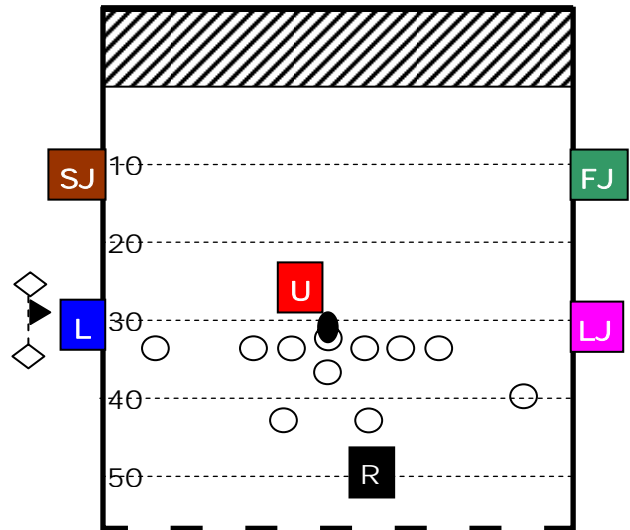

**Standard Positions**

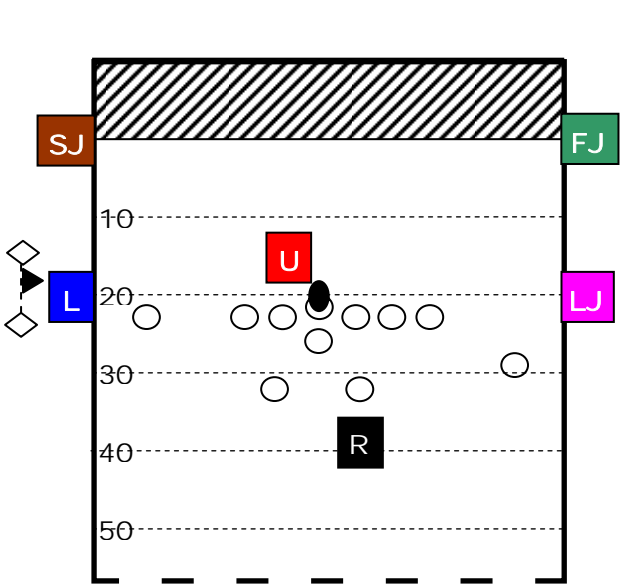

**Inside 20**

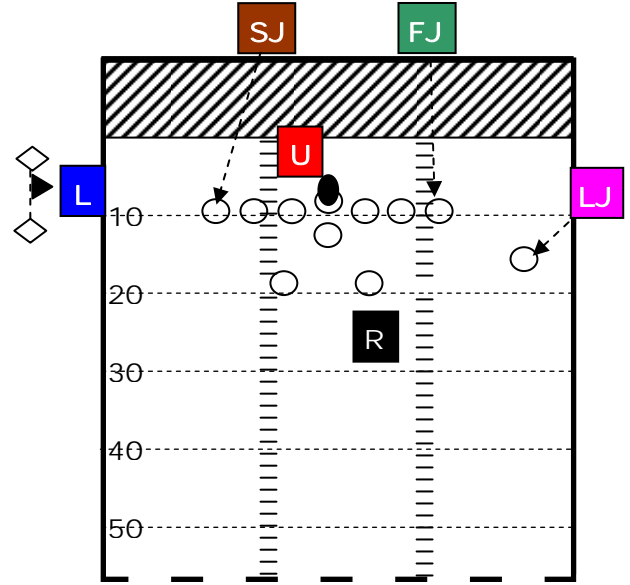

**Inside 5**



# 7

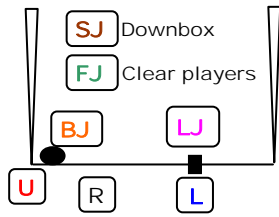

**Measurements**

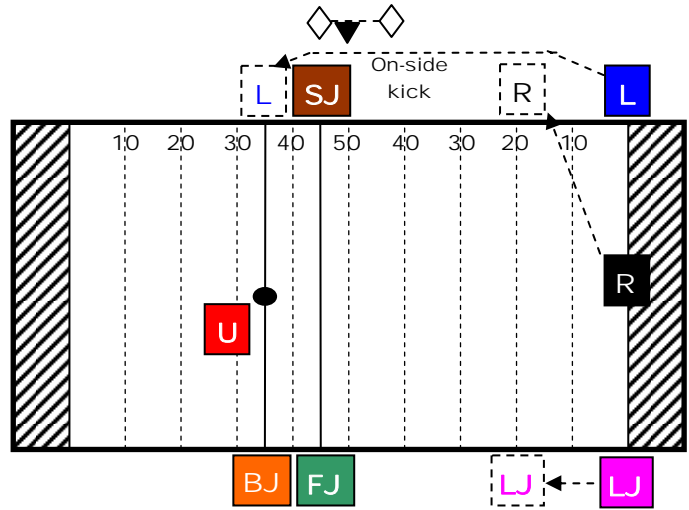

**Kickoff Positions**

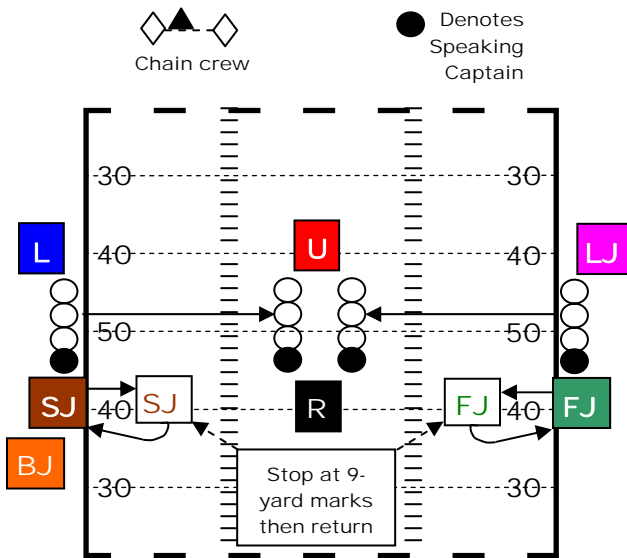

**Prior to Coin Toss**

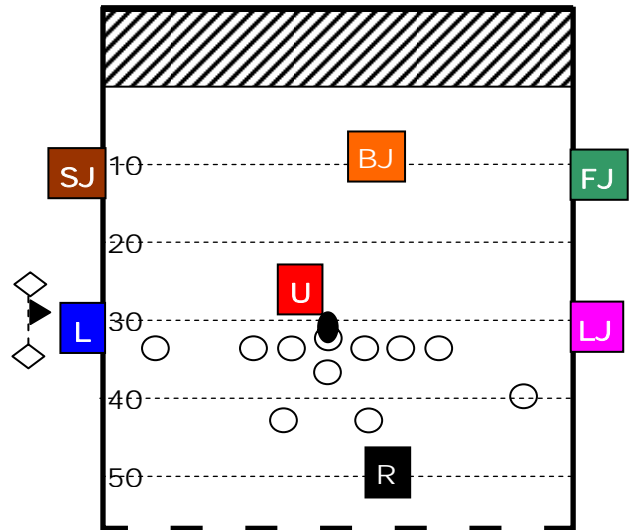

**Standard Positions**

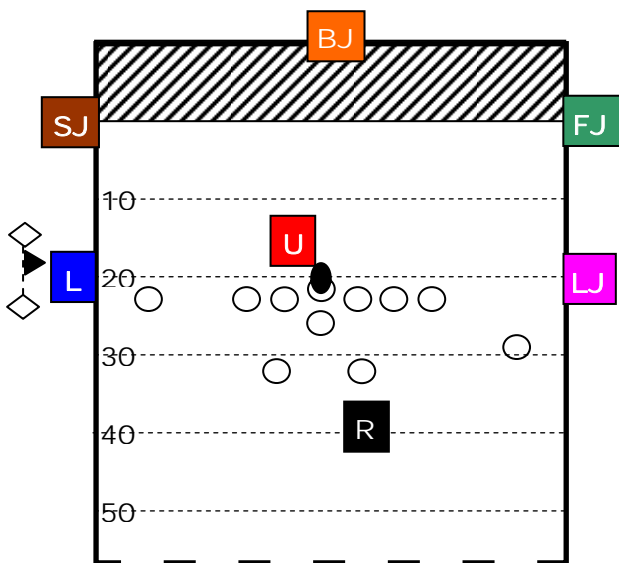

**Inside 20**

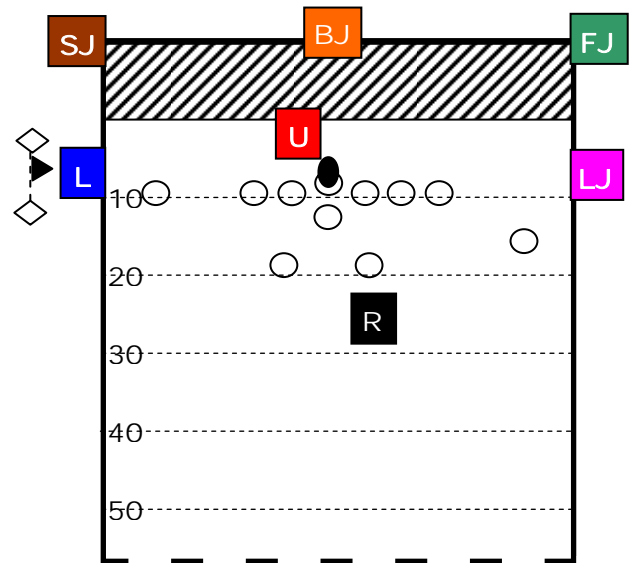

**Inside 5**

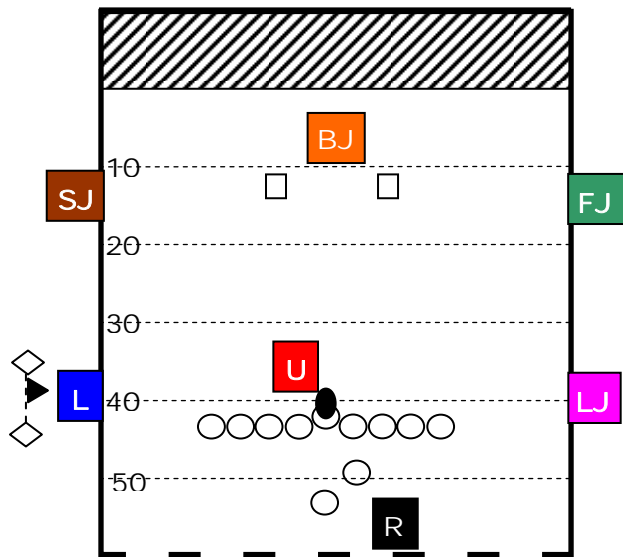

**Scrimmage kick**

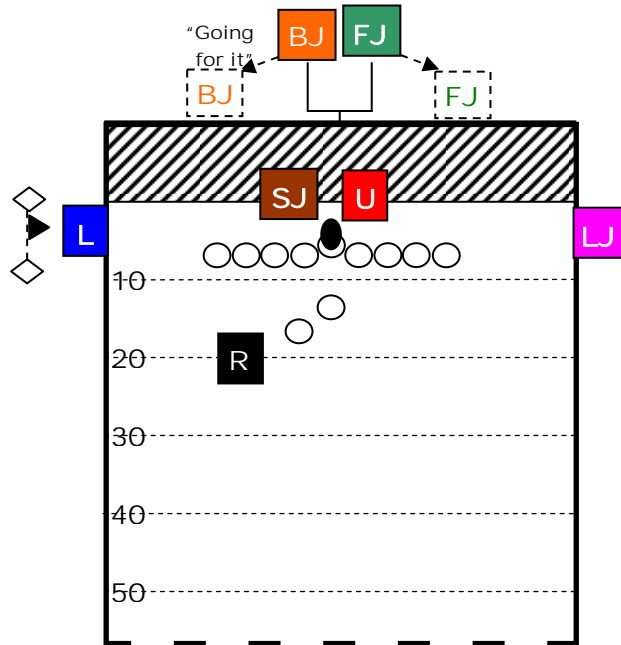

**1-point PAT or field goal attempt**

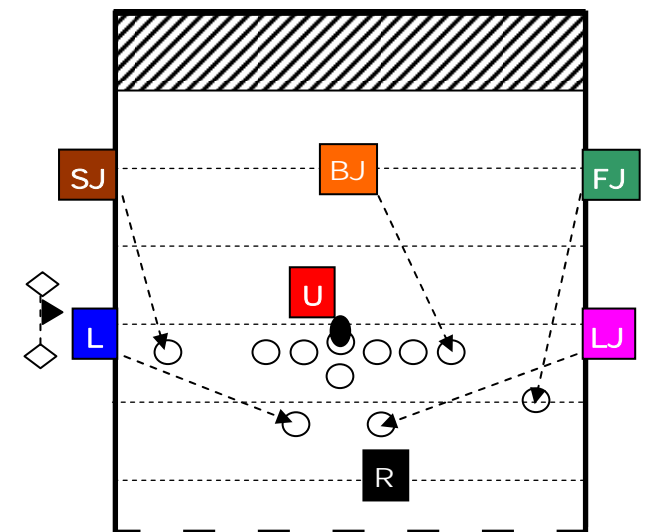

**Initial keys: Standard**  
(BJ has second man in on strong side)

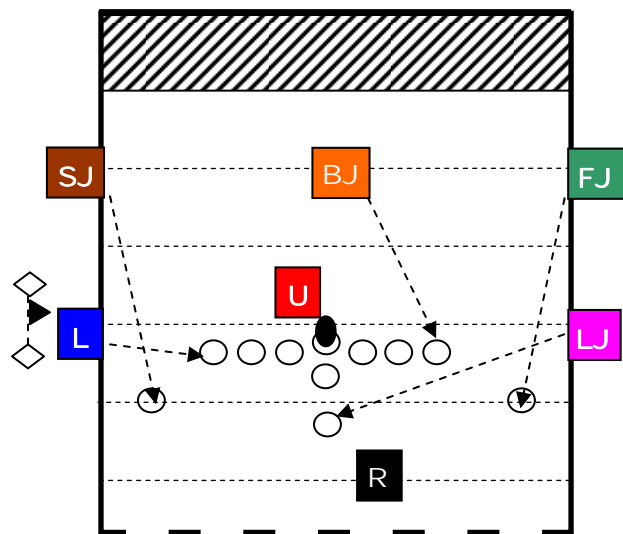

**Balanced formation**  
(Strength declared to LJ's side)

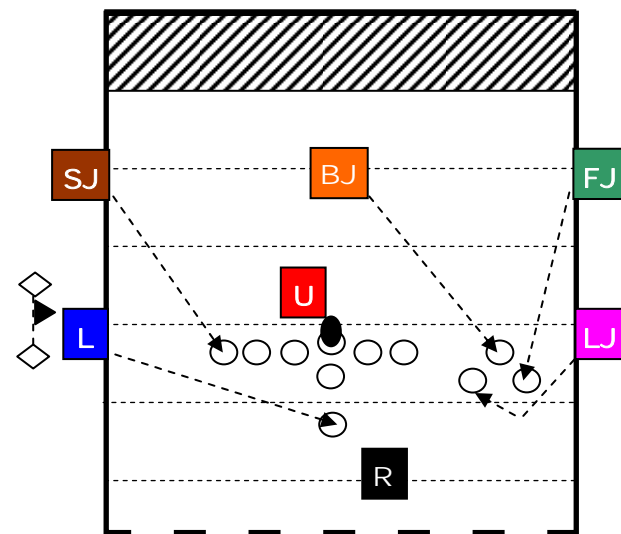

**Trips**

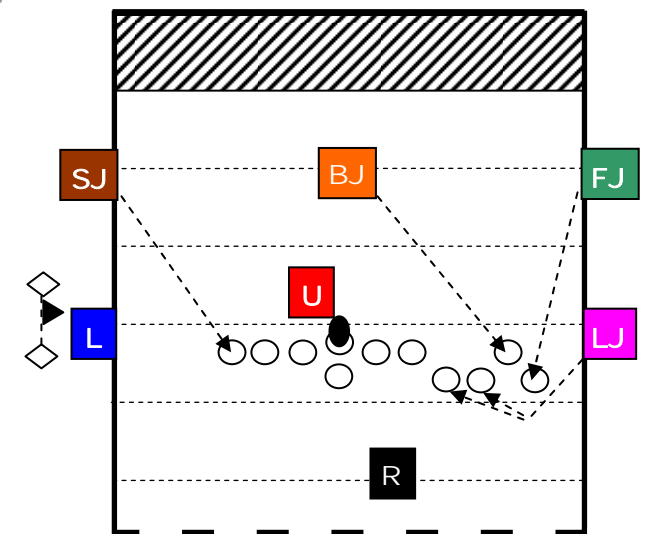

**Four receivers**  
(If stacked, deep wing has front man, BJ second)